



CSH 1 / CSH 2

CAR SEAT HEATER

Installation manual

Ensure that the harnesses are not kinked or damaged as you install them in the car. Additional harnesses that you install must be secured with cable ties.

If the specified PIN chambers are occupied, bridges, double crimps or twin-lead terminals must be used.

All harnesses must be installed correctly with power position according this instruction.

The cables/lines are not allowed to be altered, and should be hidden within the car.

The pad must be laid within the fillisters for trimming wires of seats and backrests.

The width of the pad is limited with the fillisters of foam

The heating area is not allowed cut or drilled. There are two rules must be followed as you cutting the pad:

When a rectangle aperture is needed, the pad must be cut along perpendicular direction to the electrode tape. The electrode tapes must not be cut off. If the pad is longer than needed, the pad should be cut at the bottom side along perpendicular

direction to the electrode tape.

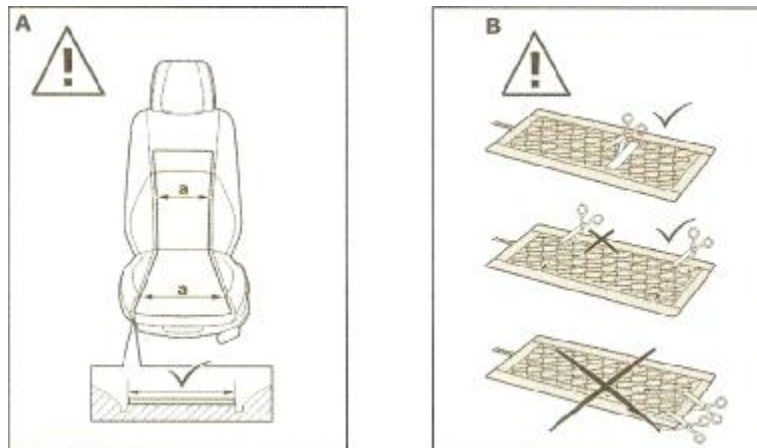

1 Preparations



Refer to the safety instructions for handling airbag modules and pyrotechnical belt tensioners. Incorrect handling may cause the pyrotechnical belt tensioner or side airbag to deploy and thus cause injuries.

The following components must be removed first of all:

- I Glove compartment
- I Footwell trim on the passenger side
- I Front seat, left or right
- I Backrest cover, left or right
- I Seat cover, left or right
- I Pedal trim

Special Tools required

Pliers

2 Part lists

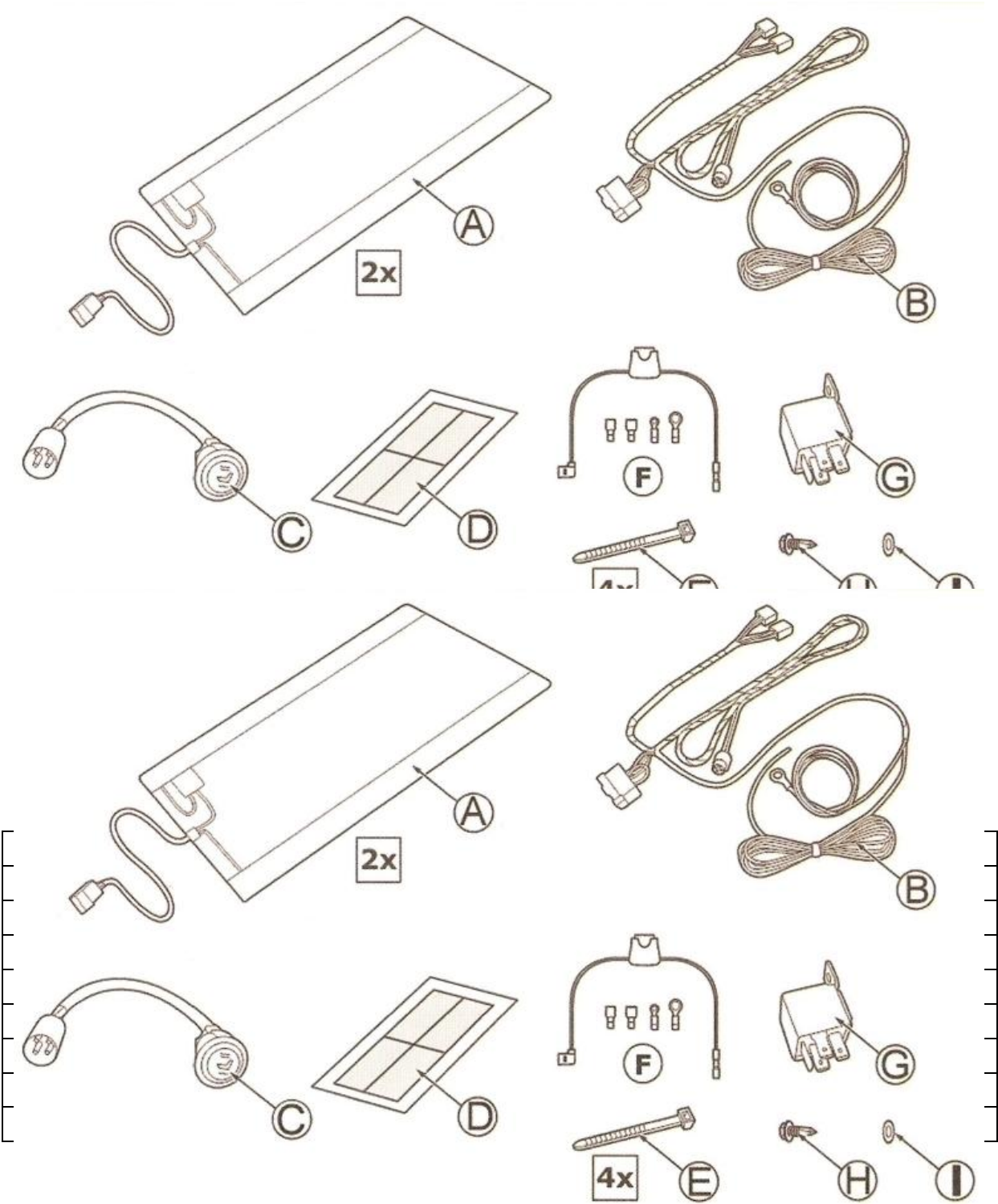

3 Installation steps

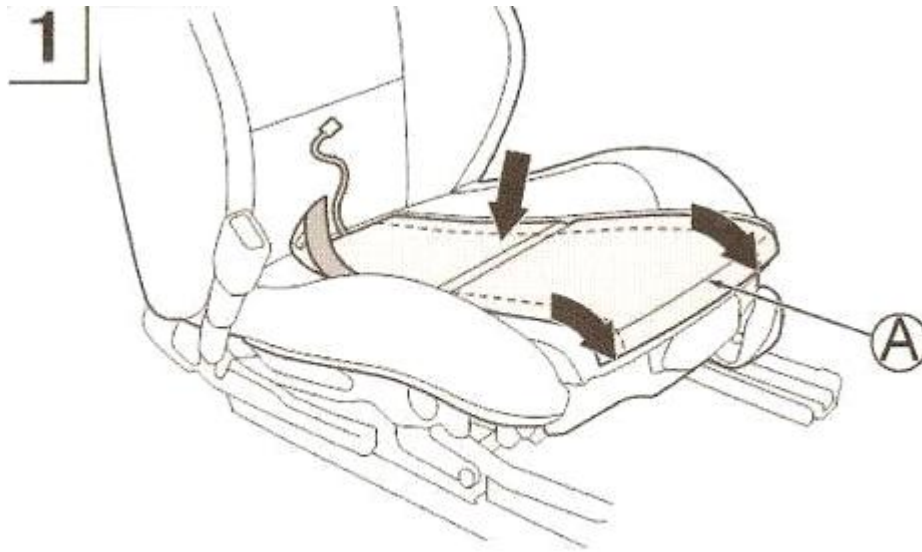

The heating pad should be unfolded as illustrated in above

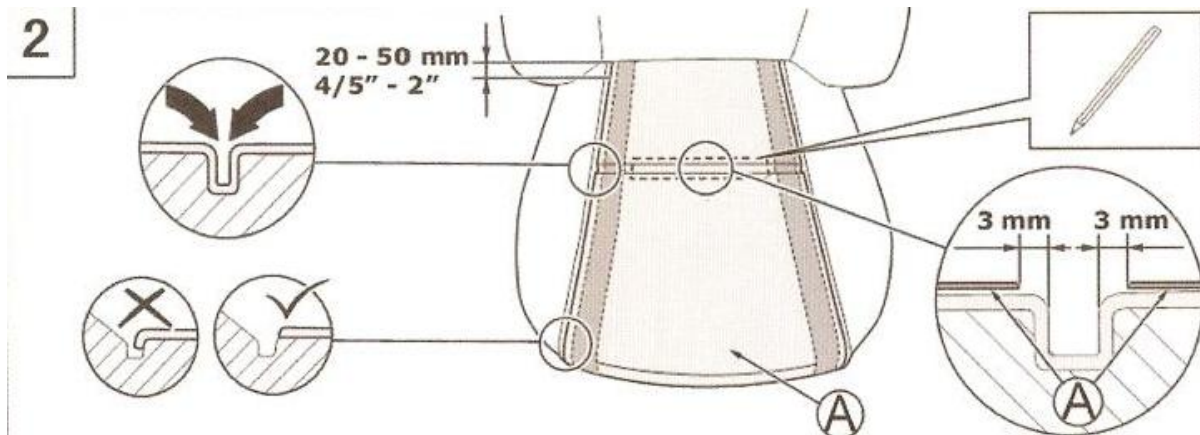

There are at least 3mm between the pad and fillisters after the pad is unfolded nicely. The heating area can not be put inside of any fillisters.

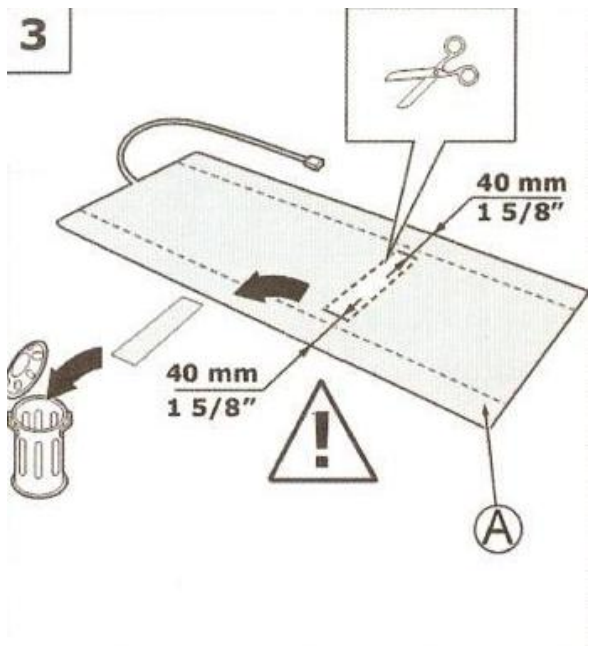

If there are fillisters for trimming wires on the seat or backrest, the heating area of pad within the two electrode tapes should be delineated with pencil or marker pen and cut into a rectangle aperture with 40mm width as illustrated in 3.

The foam opposite to the temperature controller should be cut into a hole, in order to level the pad.



5

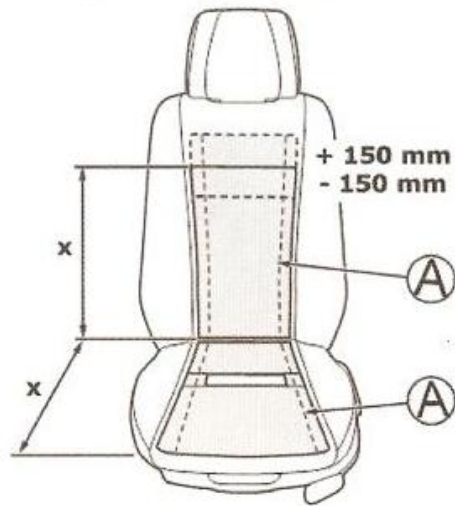

There are $\pm 150\text{mm}$ cutting deviations of either seat or backrest.

6

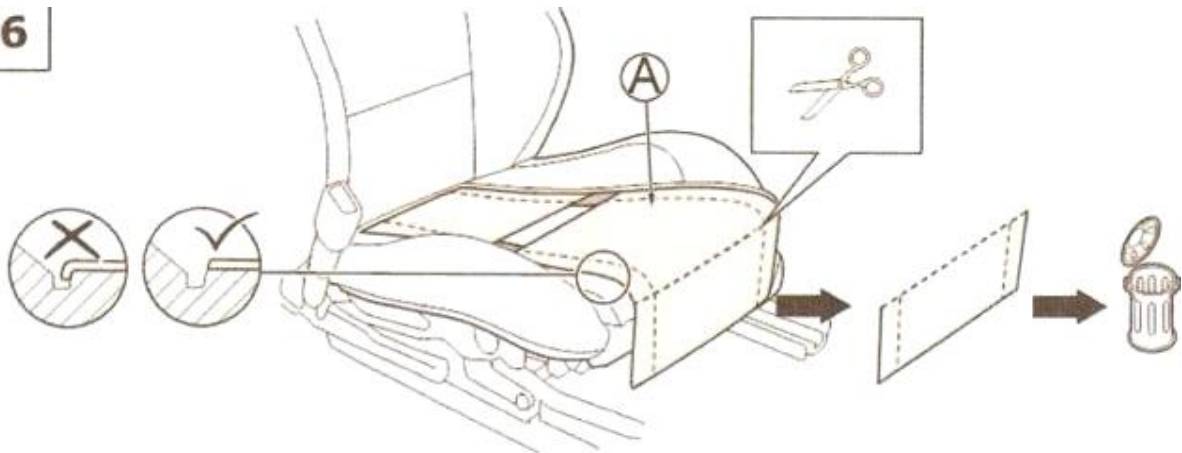

Superfluous parts of the pad must be cut off.

7

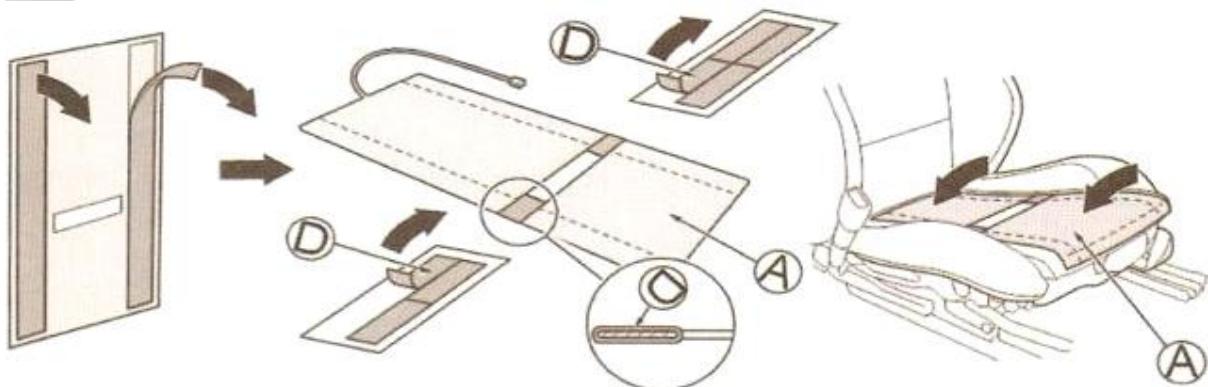

The electrodes on the ends of rectangle aperture (s) must be wrapped with double-coated adhesive protection tape \textcircled{D} .

The backing should be ripped when the pads are installed.

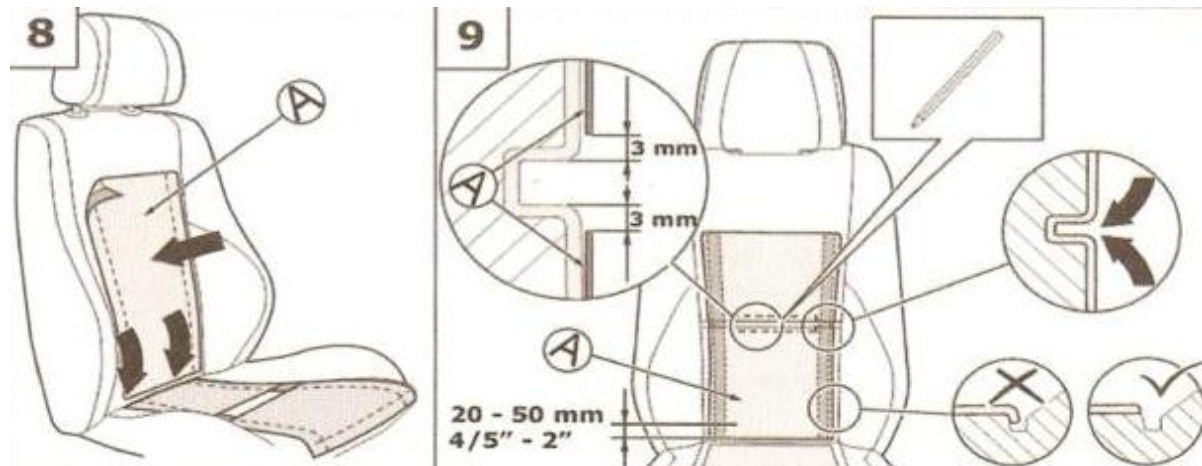

The backrest of heating pad should be unfold as illustrated in 8
 The installation of the backrest on the fillisters is the same as 2 & 4.
 There are at least 3mm between the pad and fillisters after the pad is unfolded nicely.
 The heating area can not be put inside of any fillisters.

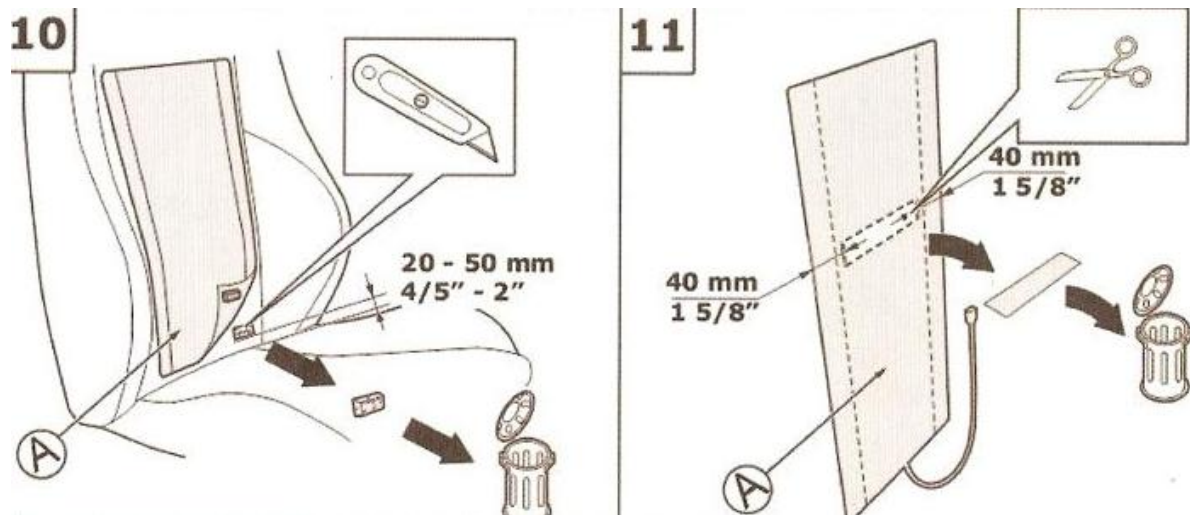

The foam opposite to the temperature controller should be cut into a hole, in order to level the pad.
 If there are fillisters for trimming wires on the seat or backrest, the heating area of pad within the two electrode tapes should be delineated with pencil or marker pen and cut into a rectangle aperture with 40mm width as illustrated in 11.

12

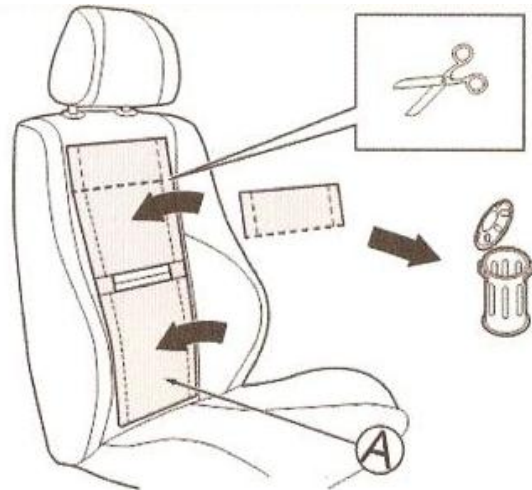
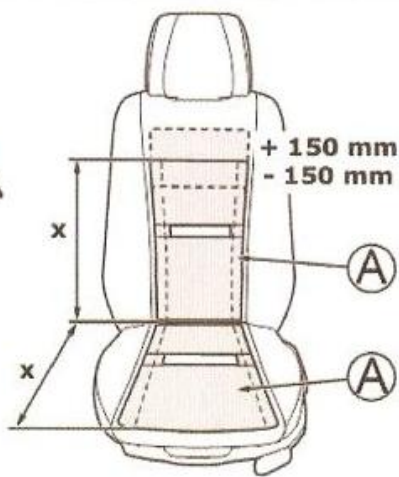

There are ± 150 mm cutting deviations of either seat or backrest.
Superfluous parts of the pad must be cut off.
The backing should be ripped when the pads are installed.

13

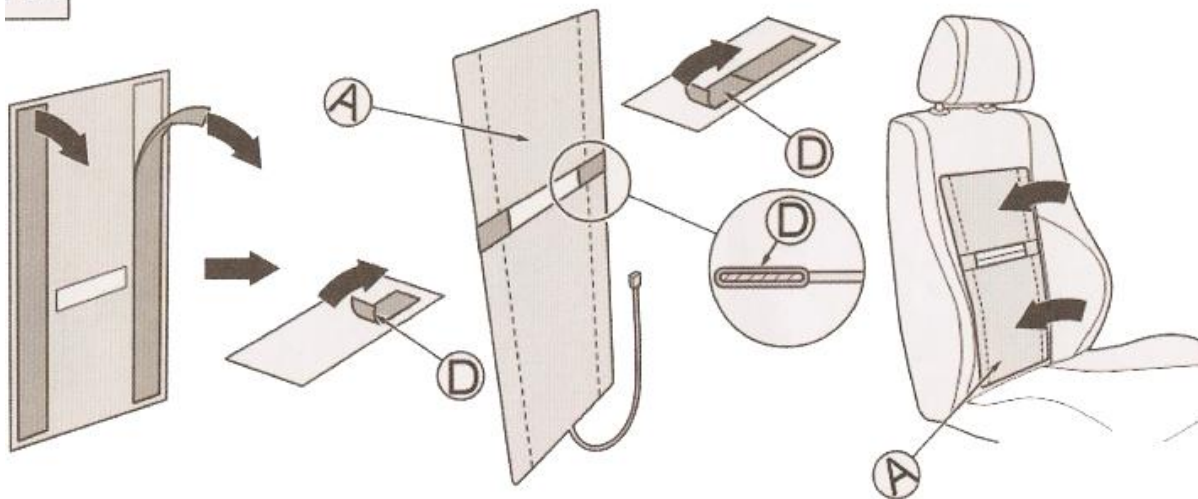

The electrodes on the ends of rectangle aperture (s) must be wrapped with doubt-coated adhesive protection tape **D**.

14

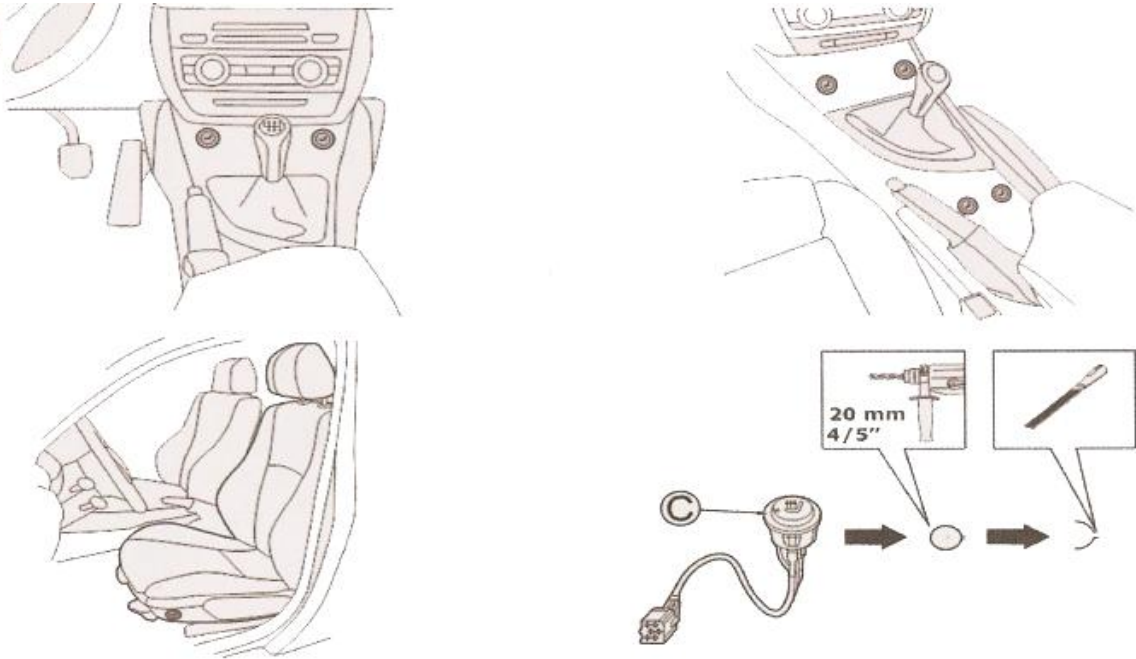

At the proper position such as near gear-level, flanks of the seat, auxiliary fascia console, etc. a hole is drilled to install the switch. The fillisters for reinforcing ribs of the switch should be filed.

15

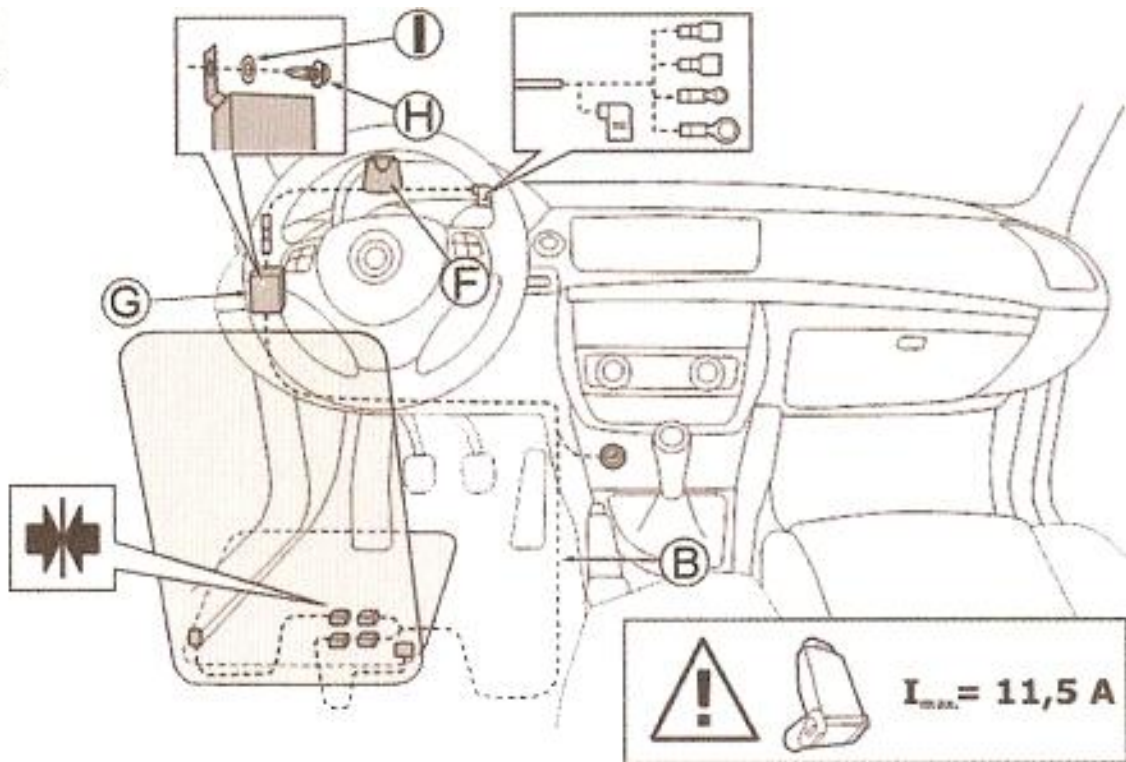



The harness connecting with seat pad and backrest pad is distributed as above. All connector clips must be connected.

The relay **G** is connected with main power supply cable and bound with screw **H** for grounding and spacer **D**.

Note: The current the pad is 11.5 Amp. max.

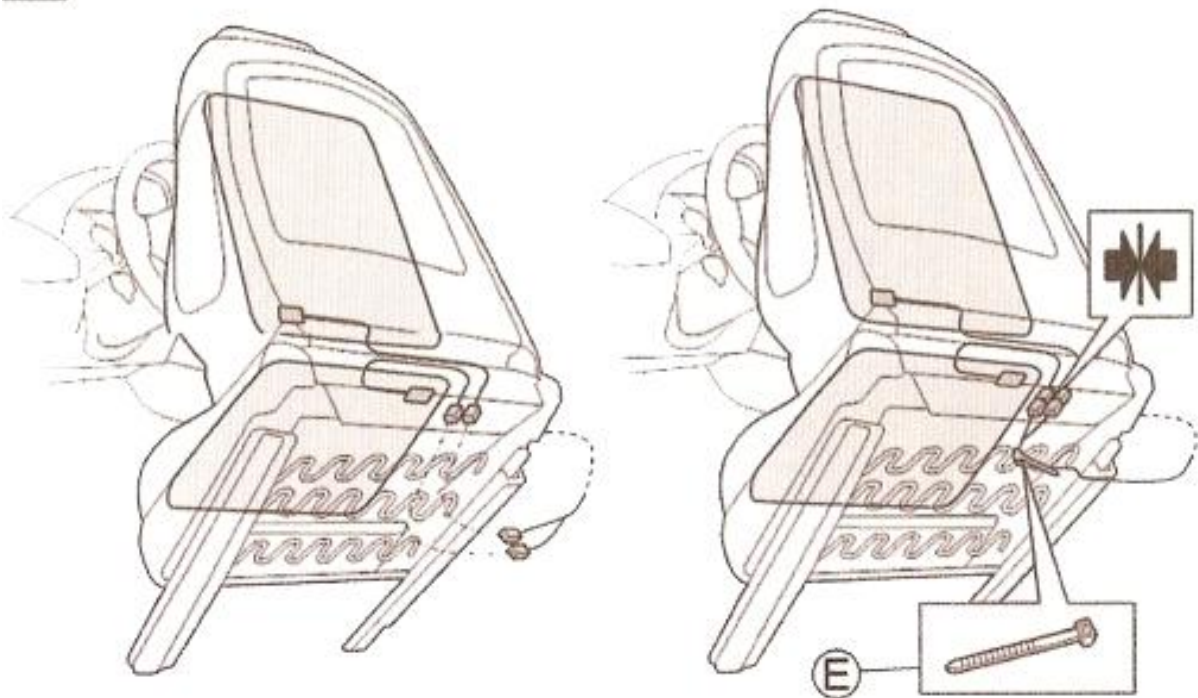
16



The harness connecting with seat pad and backrest pad is distributed as above. The harness should be bound with Nylon cable tie 

17



Concluding the work
Turn on the key of the car to ON position, and the switch, after 2 - 5 minutes, to check the temperature changes on the surface of the seat and backrest.

Wiring diagram CSH 1

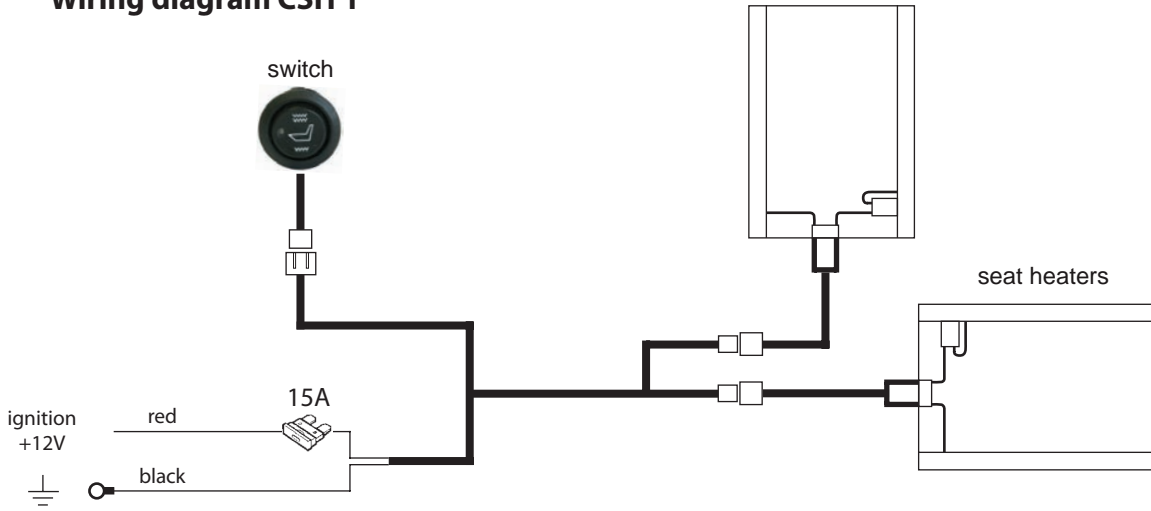

Wiring diagram CSH 2

